

50-350kg

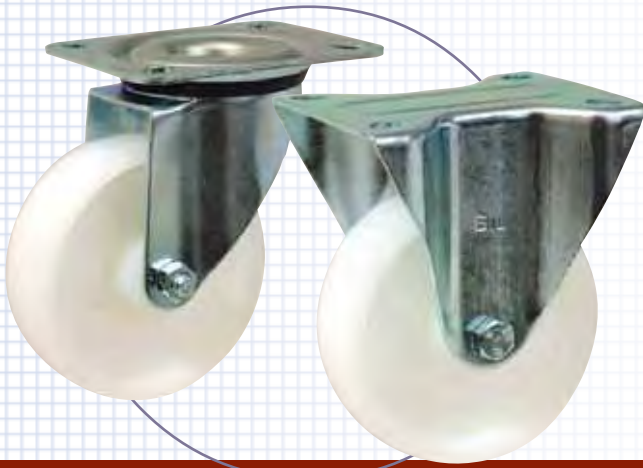

BZMM SERIES

Zinc-plated, pressed steel housing with double ball race in swivelhead.

Available with top plate or single bolthole fixing.

BZMM SERIES INDUSTRIAL

WHEEL CODE		NY	PS	GR	BS	RN	PN				
Wheel diam or fixed (mm)	Swivel radius (mm)	White nylon	Black rubber on black polypropylene	Grey rubber on black polypropylene	Black rubber on steel disc centre	Blue rubber on black nylon	Brown polyurethane on white nylon				
80	S	25 NY=30 RN=35 PN=30	105	A	78 108*	BZMM80NY 90kg	BZMM80PS 50kg	BZMM80GR 50kg	-	BZMM80RN 120kg	BZMM80PN 100kg
						BZMM80NYB 90kg	BZMM80PSB 50kg	BZMM80GRB 50kg	BZMM80BSB 50kg	-	BZMM80PNB 100kg
80	F	25 NY=30 RN=35 PN=30	105	A	-	BZMMF80NY 90kg	BZMMF80PS 50kg	BZMMF80GR 50kg	-	BZMMF80RN 120kg	BZMMF80PN 100kg
						BZMMF80NYB 90kg	BZMMF80PSB 50kg	BZMMF80GRB 50kg	BZMMF80BSB 50kg	-	BZMMF80PNB 100kg
100	S	30 RN=32	128	A	88 128*	BZMM100NY 125kg	BZMM100PS 70kg	BZMM100GR 70kg	-	BZMM100RN 150kg	BZMM100PN 150kg
						BZMM100NYB 125kg	BZMM100PSB 70kg	BZMM100GRB 70kg	BZMM100BSB 70kg	BZMM100RNB 150kg	BZMM100PNB 150kg
100	F	30 RN=32	128	A	-	BZMMF100NY 125kg	BZMMF100PS 70kg	BZMMF100GR 70kg	-	BZMMF100RN 150kg	BZMMF100PN 150kg
						BZMMF100NYB 125kg	BZMMF100PSB 70kg	BZMMF100GRB 70kg	BZMMF100BSB 70kg	BZMMF100RNB 150kg	BZMMF100PNB 150kg
125	S	37.5 NY=35 RN=35 PN=35	155	A	107 135*	BZMM125NY 200kg	BZMM125PS 90kg	BZMM125GR 90kg	-	BZMM125RN 200kg	BZMM125PN 200kg
						BZMM125NYB 200kg	BZMM125PSB 90kg	BZMM125GRB 90kg	BZMM125BSB 90kg	BZMM125RNB 200kg	BZMM125PNB 200kg
125	F	37.5 NY=35 RN=35 PN=35	155	A	-	BZMMF125NY 200kg	BZMMF125PS 90kg	BZMMF125GR 90kg	-	BZMMF125RN 200kg	BZMMF125PN 200kg
						BZMMF125NYB 200kg	BZMMF125PSB 90kg	BZMMF125GRB 90kg	BZMMF125BSB 90kg	BZMMF125RNB 200kg	BZMMF125PNB 200kg
150	S	40 RN=50	190	B	135 169*	BZMM150NY 350kg	-	-	-	BZMM150RN 300kg	-
						BZMM150NYB 350kg	-	-	-	BZMM150RNB 300kg	-
150	F	40 RN=50	190	B	-	BZMMF150NY 350kg	-	-	-	BZMMF150RN 300kg	-
						BZMMF150NYB 350kg	-	-	-	BZMMF150RNB 300kg	-
160	S	45 RN=50	195	B	140 174*	BZMM160NY 350kg	BZMM160PS 160kg	BZMM160GR 160kg	-	BZMM160RN 300kg	-
						BZMM160NYB 350kg	BZMM160PSB 160kg	BZMM160GRB 160kg	BZMM160BSB 160kg	BZMM160RNB 300kg	BZMM160PNB 350kg
160	F	45 RN=50	195	B	-	BZMMF160NY 350kg	BZMMF160PS 160kg	BZMMF160GR 160kg	-	BZMMF160RN 300kg	-
						BZMMF160NYB 350kg	BZMMF160PSB 160kg	BZMMF160GRB 160kg	BZMMF160BSB 160kg	BZMMF160RNB 300kg	BZMM160PNB 350kg
200	S	50	235	B	167 188*	BZMM200NY 350kg	BZMM200PS 205kg	BZMM200GR 205kg	-	BZMM200RN 350kg	BZMM200PN 350kg
						BZMM200NYB 350kg	BZMM200PSB 205kg	BZMM200GRB 205kg	BZMM200BSB 205kg	BZMM200RNB 350kg	BZMM200PNB 350kg
200	F	50	235	B	-	BZMMF200NY 350kg	BZMMF200PS 205kg	BZMMF200GR 205kg	-	BZMMF200RN 350kg	BZMMF200PN 350kg
						BZMMF200NYB 350kg	BZMMF200PSB 205kg	BZMMF200GRB 205kg	BZMMF200BSB 205kg	BZMMF200RNB 350kg	BZMMF200PNB 350kg

Braked castors (swivel and wheelbrakes)

add to code: SWB

Threadguards (available on request)

add to code: G

Single bolthole castor (12mm)

add to code: BH12

* Swivel radius when brakes are fitted

WHEEL BEARING KEY

- Plain bore
- Needle roller
- Ball journal

AVAILABLE WHEEL TYPES (for full wheel specifications refer to pages indicated)



NY = p89

PS = p96

GR = p94

BS = p97

RN = p101

PN = p107

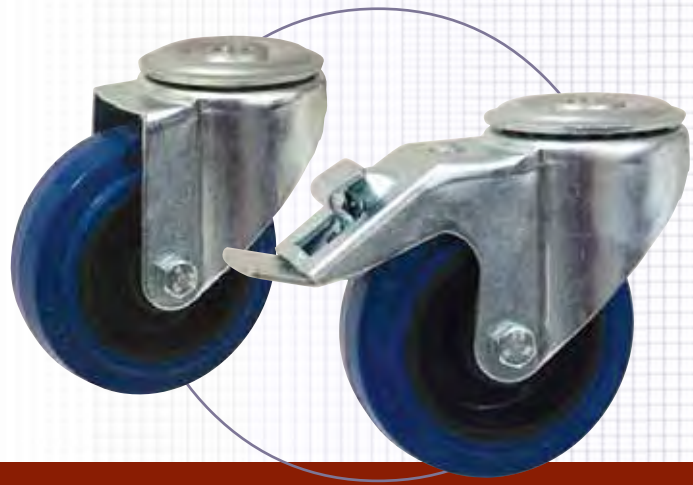
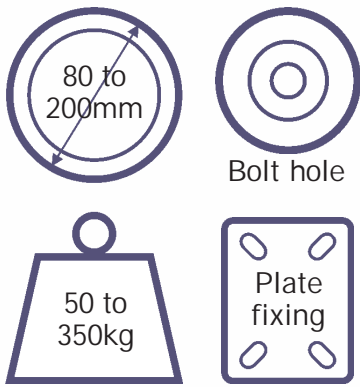

50-350kg

PLATE TYPES AND DIMENSIONS (mm)

Type A

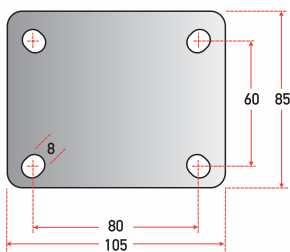

Type B

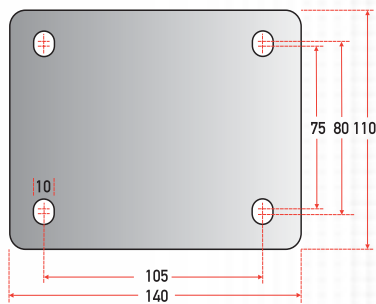

Single bolthole
add to code: BH12

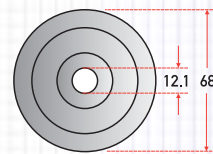

wheel diameters... 80 100 125

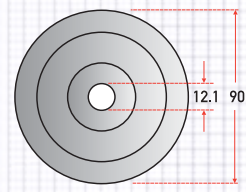

wheel diameters... 150 160 200

Alternative fittings

SQUARE EXPANDERS



Tube section	Range for inside diameter of tube (mm)	Plug length (mm)	Plug material	Product code
Square	18.5 to 21.0	70	Nylon	BZEXS185/21
	21.5 to 24.0	70		BZEXS215/24
	25.0 to 30.0	70		BZEXS25/30

ROUND EXPANDERS



Tube section	Range for inside diameter of tube (mm)	Plug length (mm)	Plug material	Product code
Round	18.5 to 21.0	70	Nylon	BZEXR185/21
	21.5 to 24.0	70		BZEXR215/24
	25.0 to 30.0	70		BZEXR25/30

BZMM SERIES INDUSTRIAL



































BZWB SERIES

Heavy-duty castors specially designed for mobile waste-containers. Zinc-plated, pressed steel housing with double ball race in swivelhead.

Available with top plate fixing.

WHEEL CODE							PS	GR	BS	RN
Wheel diam (mm)	Swivel or fixed	Tread width (mm)	Overall height (mm)	Plate type	Swivel radius (mm)	Bearing type	Black rubber on black polypropylene	Grey rubber on black polypropylene	Black rubber on steel disc centre	Blue rubber on black nylon
160	S	45 RN=50	195	A	132	 BZWB160PSB 140kg	 BZWB160GRB 160kg	 BZWB160BSB 160kg	 BZWB160RNB 300kg	
						 -	 -	 -	 BZWB160RNB 300kg	
160	F	45 RN=50	195	A	-	 BZWBF160PSB 140kg	 BZWBF160GRB 160kg	 BZWBF160BSB 160kg	 BZWBF160RNB 300kg	
						 -	 -	 -	 BZWBF160RNB 300kg	
200	S	50	238	A	155	 BZWB200PSB 205kg	 BZWB200GRB 205kg	 BZWB200BSB 205kg	 BZWB200RNB 350kg	
						 -	 -	 -	 BZWB200RNB 350kg	
200	F	50	238	A	-	 BZWBF200PSB 205kg	 BZWBF200GRB 205kg	 BZWBF200BSB 205kg	 BZWBF200RNB 350kg	
						 -	 -	 -	 BZWBF200RNB 350kg	

Braked castors (swivel and wheelbrakes) add to code: SWB

For directional lock fitting add to code: DL

This castor series has a specially designed braking mechanism to enable it to still fully swivel underneath the waste bin even with the brakes released.

WHEEL BEARING KEY

-  Needle roller
-  Ball journal

AVAILABLE WHEEL TYPES (for full wheel specifications refer to pages indicated)



PS = p96

GR = p94

BS = p97

RN = p101

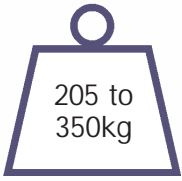
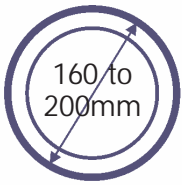
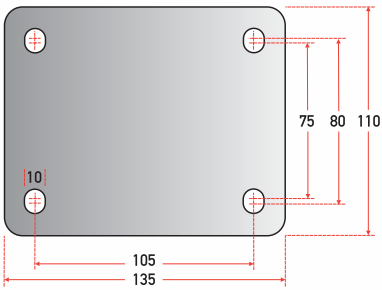

PLATE TYPES AND DIMENSIONS (mm)

Type A



Directional lock





BZH SERIES

Zinc-plated, pressed steel housing with single ball race in swivelhead.

Available with top plate fixing.

WHEEL CODE				NY	NP	RN	CI	PT			
Wheel diam (mm)	Swivel or fixed	Tread width (mm)	Overall height (mm)	Plate type	Swivel radius (mm)	Bearing type	White nylon	Red polyurethane on white nylon	Blue elastic rubber on black nylon	Black painted cast iron	Brown polyurethane on cast iron
50	S	20 RN=25	64	A	37	□	BZH50NY 50kg	–	BZH50RN 50kg	–	–
	F			B	–	□	BZH50NY 50kg	–	BZH50RN 50kg	–	–
63	S	25	83	C	55	□	BZH63NY 85kg	–	–	–	–
	F			D	–	□	BZH63NY 85kg	–	–	–	–
75	S	NY=28 RN=35 CI=32 PT=30	95	E	59 84*	□	BZH75NY 125kg	–	BZH75RN 100kg	BZH75CI 125kg	BZH75PT 125kg
75	F			F	–	□	BZH75NY 125kg	–	BZH75RN 100kg	BZH75CI 125kg	BZH75PT 125kg
100	S	40 NY=32 NP=35	127	G	77 106*	□	BZH100NYLP 250kg	BZH100NPLP 250kg	BZH100RNLP 250kg	BZH100CILP 250kg	–
						▨	BZH100NYBLP 250kg	BZH100NPBLP 250kg	BZH100RNBLP 250kg	BZH100CIBLP 250kg	BZH100PTBLP 250kg
100	F		127	H	–	□	BZH100NYLP 250kg	BZH100NPLP 250kg	BZH100RNLP 250kg	BZH100CILP 250kg	–
						▨	BZH100NYBLP 250kg	BZH100NPBLP 250kg	BZH100RNBLP 250kg	BZH100CIBLP 250kg	BZH100PTBLP 250kg
125	S	40 NY=35 NP=35	153	I	107	□	BZH125NYLP 295kg	BZH125NPLP 295kg	BZH125RNLP 250kg	BZH125CILP 295kg	–
						▨	BZH125NYBLP 295kg	BZH125NPBLP 295kg	BZH125RNBLP 250kg	BZH125CIBLP 295kg	BZH125PTBLP 295kg
125	F		153	J	–	□	BZH125NYLP 295kg	BZH125NPLP 295kg	BZH125RNLP 250kg	BZH125CILP 295kg	–
						▨	BZH125NYBLP 295kg	BZH125NPBLP 295kg	BZH125RNBLP 250kg	BZH125CIBLP 295kg	BZH125PTBLP 295kg
125	S		153	K	107	□	BZH125NYXLP 295kg	BZH125NPXLP 295kg	BZH125RNXP 250kg	BZH125CIXLP 295kg	–
						▨	BZH125NYBXP 295kg	BZH125NPBXP 295kg	BZH125RNBXP 250kg	BZH125CIBXP 295kg	BZH125PTBXP 295kg
150	S	50 NY=45 NP=40	181	K	121	□	BZH150NYXLP 650kg	BZH150NPXLP 500kg	BZH150RNXP 300kg	BZH150CIXLP 650kg	–
						▨	BZH150NYBXP 650kg	BZH150NPBXP 500kg	BZH150RNBXP 300kg	BZH150CIBXP 650kg	BZH150PTBXP 650kg

Braked castors (footbrake only)
(75mm and 100mm diameter only)

add to code: BR

12mm threaded stem (75mm diameter only)

add to code: ST12

*Swivel radius when brakes are fitted

WHEEL BEARING KEY

- Plain bore
- ▨ Needle roller

AVAILABLE WHEEL TYPES (for full wheel specifications refer to pages indicated)

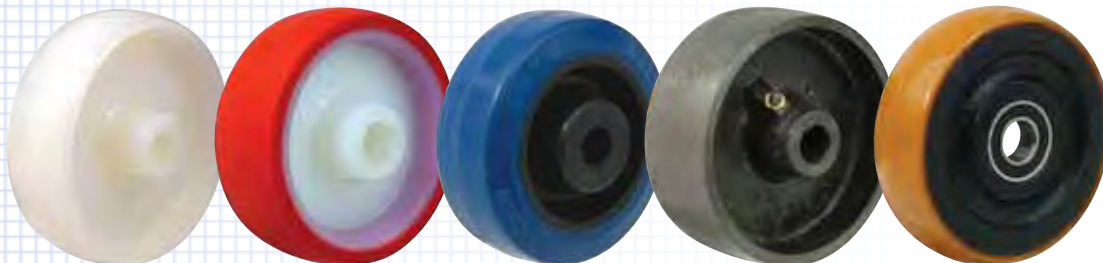

NY = p89

NP = p106

RN = p101

CI = p90

PT = p111

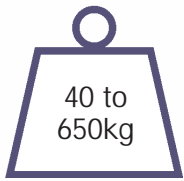
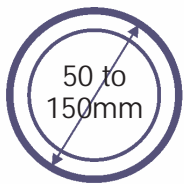

40-650kg

PLATE TYPES AND DIMENSIONS (mm)

Type A

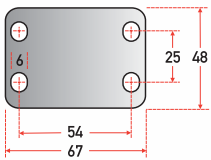

Type B

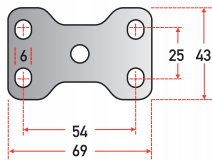

Type C

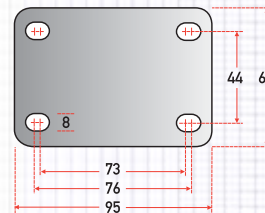

Type D

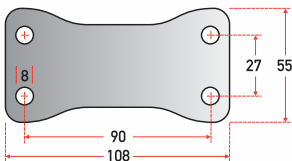

Type E

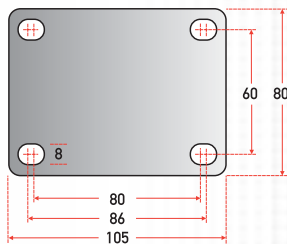

Type F

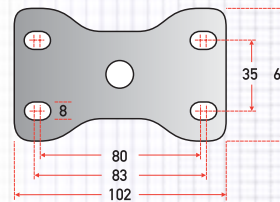

Type G

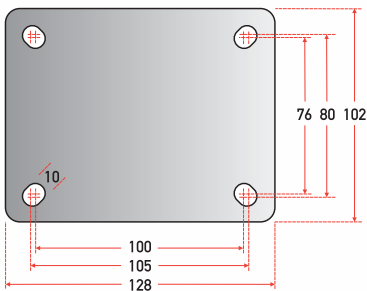

Type H

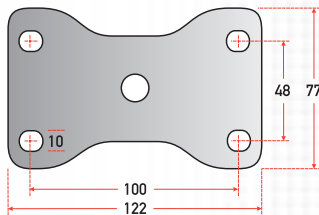

Type I

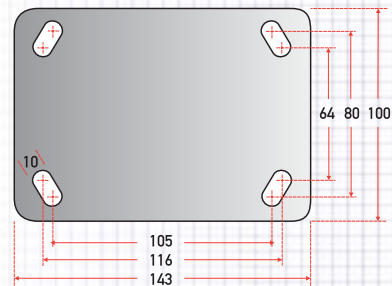

Type J

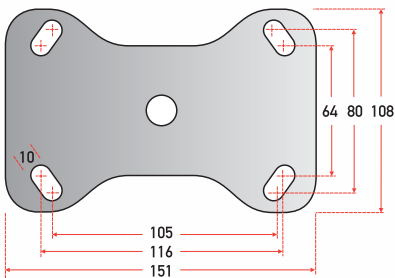

Type K

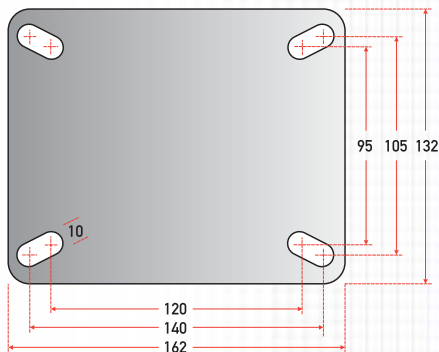

BZH SERIES INDUSTRIAL



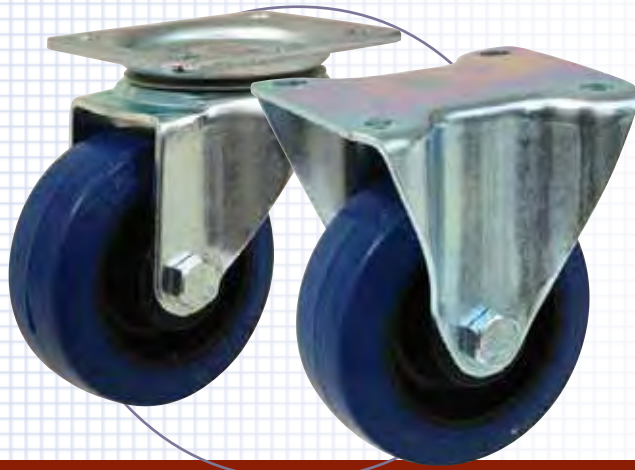

BZH/BZPH SERIES

Zinc-plated, pressed steel housing with double ball race in swivelhead.

Available with top plate or single bolthole fixing.

WHEEL CODE		NY	NP	RN	CI	PT					
Wheel diam or (mm)	Swivel or fixed	Tread width (mm)	Overall height (mm)	Plate type	Swivel radius (mm)	Bearing type	White nylon	Red polyurethane on white nylon	Blue elastic rubber on black nylon	Black painted cast iron	Brown polyurethane on cast iron

100	S	40	128	A	90		BZH100NY 270kg	BZH100NP 250kg	BZH100RN 250kg	BZH100CI 270kg	-
				A	116*		BZH100NYB 270kg	BZH100NPB 250kg	BZH100RNB 250kg	BZH100CIB 270kg	BZH100PTB 300kg
100	F	40	128	A	-		BZHF100NY 270kg	BZHF100NP 250kg	BZHF100RN 250kg	BZHF100CI 270kg	-
				A	-		BZHF100NYB 270kg	BZHF100NPB 250kg	BZHF100RNB 250kg	BZHF100CIB 270kg	BZHF100PTB 300kg
100	S	40	129	B	90		BZPH100NY 270kg	BZPH100NP 250kg	BZPH100RN 250kg	BZPH100CI 270kg	-
				B	116*		BZPH100NYB 270kg	BZPH100NPB 250kg	BZPH100RNB 250kg	BZPH100CIB 270kg	BZPH100PTB 300kg
100	F	40	129	C	-		BZPHF100NY 270kg	BZPHF100NP 250kg	BZPHF100RN 250kg	BZPHF100CI 270kg	-
				C	-		BZPHF100NYB 270kg	BZPHF100NPB 250kg	BZPHF100RNB 250kg	BZPHF100CIB 270kg	BZPHF100PTB 300kg
125	S	40	155	A	93		BZH125NY 300kg	BZH125NP 300kg	BZH125RN 250kg	BZH125CI 300kg	-
				A	120*		BZH125NYB 300kg	BZH125NPB 300kg	BZH125RNB 250kg	BZH125CIB 300kg	BZH125PTB 300kg
125	F	40	155	A	-		BZHF125NY 300kg	BZHF125NP 300kg	BZHF125RN 250kg	BZHF125CI 300kg	-
				A	-		BZHF125NYB 300kg	BZHF125NPB 300kg	BZHF125RNB 250kg	BZHF125CIB 300kg	BZHF125PTB 300kg
125	S	40	157	B	93		BZPH125NY 300kg	BZPH125NP 300kg	BZPH125RN 300kg	BZPH125CI 300kg	-
				B	120*		BZPH125NYB 300kg	BZPH125NPB 300kg	BZPH125RNB 300kg	BZPH125CIB 300kg	BZPH125PTB 300kg
125	F	40	157	C	-		BZPHF125NY 300kg	BZPHF125NP 300kg	BZPHF125RN 250kg	BZPHF125CI 300kg	-
				C	-		BZPHF125NYB 300kg	BZPHF125NPB 300kg	BZPHF125RNB 250kg	BZPHF125CIB 300kg	BZPHF125PTB 300kg
125	S	50	165	A	157		BZWH125NY 300kg	BZWH125NP 300kg	-	BZWH125CI 300kg	-
				A	157		BZWH125NYB 300kg	BZWH125NPB 300kg	BZWH125RNBS 250kg	BZWH125CIB 300kg	-
				A	157		BZWH125NYBJSWB 300kg	BZWH125NPBJ 300kg	-	BZWH125CIBJ 300kg	BZWH125PTBJ 300kg
150	S	50	188	B	128		BZPH150NY 500kg	BZPH150NP 500kg	BZPH150RN 300kg	BZPH150CI 500kg	-
				B	165*		BZPH150NYB 500kg	BZPH150NPB 500kg	BZPH150RNB 300kg	BZPH150CIB 500kg	BZPH150PTB 500kg
				B	165*		BZPH150NYBJ 500kg	BZPH150NPBJ 500kg	-	BZPH150CIBJ 500kg	BZPH150PTBJ 500kg
150	F	50	188	C	-		BZPHF150NY 500kg	BZPHF150NP 500kg	BZPHF150RN 300kg	BZPHF150CI 500kg	-
				C	-		BZPHF150NYB 500kg	BZPHF150NPB 500kg	BZPHF150RNB 300kg	BZPHF150CIB 500kg	BZPHF150PTB 500kg
				C	-		BZPHF150NYBJ 500kg	BZPHF150NPBJ 500kg	-	BZPHF150CIBJ 500kg	BZPHF150PTBJ 500kg
200	S	50	238	B	153		BZPH200NY 500kg	BZPH200NP 500kg	BZPH200RN 400kg	BZPH200CI 500kg	-
				B	165*		BZPH200NYB 500kg	BZPH200NPB 500kg	BZPH200RNB 400kg	BZPH200CIB 500kg	BZPH200PTB 500kg
				B	165*		BZPH200NYBJ 500kg	BZPH200NPBJ 500kg	-	BZPH200CIBJ 500kg	BZPH200PTBJ 500kg
200	F	50	238	C	-		BZPHF200NY 500kg	BZPHF200NP 500kg	BZPHF200RN 400kg	BZPHF200CI 500kg	-
				C	-		BZPHF200NYB 500kg	BZPHF200NPB 500kg	BZPHF200RNB 400kg	BZPHF200CIB 500kg	BZPHF200PTB 500kg
				C	-		BZPHF200NYBJ 500kg	BZPHF200NPBJ 500kg	-	BZPHF200CIBJ 500kg	BZPHF200PTBJ 500kg

* Swivel radius when brakes are fitted

AVAILABLE WHEEL TYPES (for full wheel specifications refer to pages indicated)

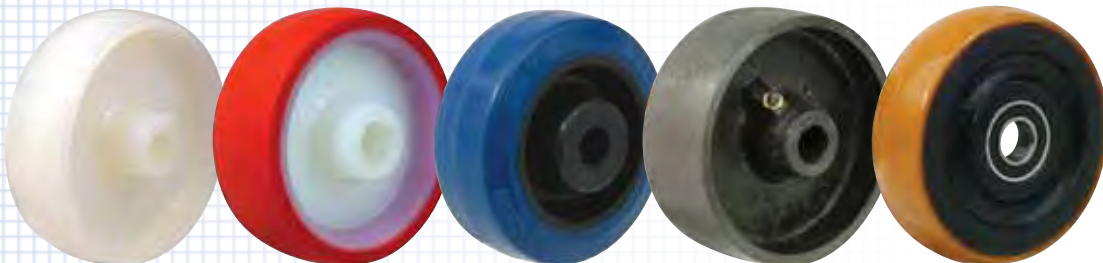

NY = p89

NP = p106

RN = p101

CI = p90

PT = p111

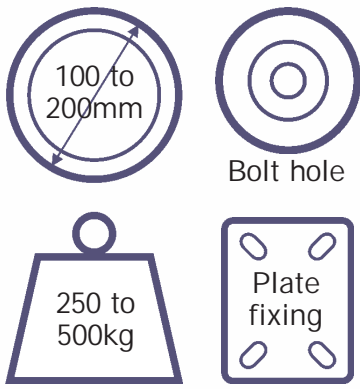

250-500kg

PLATE TYPES AND DIMENSIONS (mm)

Type A

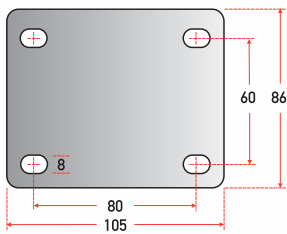

Type B

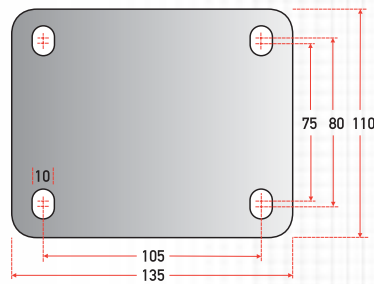

Type C

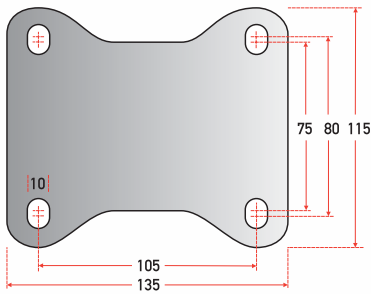

Single bolthole

add to code: BH12

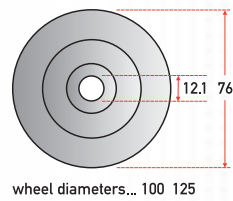

WHEEL BEARING KEY	
	Plain bore
	Needle roller
	Ball journal

Braked castors (swivel and wheelbrakes)	add to code:	SWB
Threadguards (available on request)	add to code:	G
Single bolthole castor (12mm) (100mm to 125mm diameter only)	add to code:	BH12

BZH/BZPH SERIES INDUSTRIAL





BZP SERIES

Zinc-plated, pressed steel housing with sealed double ball race in swivelhead.

Available with top plate fixing.

WHEEL CODE		NY	ER	CR	PT					
Wheel diam (mm)	Swivel or fixed	Tread width (mm)	Overall height (mm)	Plate type	Swivel radius (mm)	Bearing type	White nylon	Black elastic rubber on aluminium	Black elastic rubber on cast iron	Brown polyurethane on cast iron
100	S	40 CI=50	142	A	95 150*	BZP100NY 400kg	-	-	-	-
						BZP100NYBJ 400kg	-	BZP100CRBJ 210kg	BZP100PTBJ 300kg	
100	F	40 CI=50	142	A	-	BZP100NY 400kg	-	-	-	-
						BZPF100NYBJ 400kg	-	BZPF100CRBJ 210kg	BZPF100PTBJ 300kg	
125	S	50 PT=40 NY=45	164	A	118 150*	BZP125NY 750kg	-	-	-	-
						BZP125NYB 750kg	-	BZP125CRB 300kg	-	
						BZP125NYBJ 750kg	BZP125ERBJ 225kg	BZP125CRBJ 300kg	BZP125PTBJ 400kg	
125	F	50 PT=40 NY=45	164	A	-	BZPF125NY 750kg	-	-	-	-
						BZPF125NYB 750kg	-	BZPF125CRB 300kg	-	
						BZPF125NYBJ 750kg	BZPF125ERBJ 225kg	BZPF125CRBJ 300kg	BZPF125PTBJ 400kg	
150	S	50 NY=45	194	A	130 150*	BZP150NY 800kg	-	-	-	-
						BZP150NYB 800kg	-	BZP150CRB 300kg	BZP150PTB 750kg	
						BZP150NYBJ 800kg	-	BZP150CRBJ 300kg	BZP150PTBJ 750kg	
150	F	50 NY=45	194	A	-	BZPF150NY 800kg	-	-	-	-
						BZPF150NYB 800kg	-	BZPF150CRB 300kg	BZPF150PTB 750kg	
						BZPF150NYBJ 800kg	-	BZPF150CRBJ 300kg	BZPF150PTBJ 750kg	
160	S	50	199	A	135 150*	-	-	-	-	-
						-	-	-	-	
						-	BZP160ERBJ 350kg	-	-	
160	F	50	199	A	-	-	-	-	-	-
						-	-	-	-	
						-	BZPF160ERBJ 350kg	-	-	

Braked castors (swivel and wheelbrakes) add to code: SWB

* swivel radius when brakes fitted

WHEEL BEARING KEY

- Plain bore
- Needle roller
- Ball journal

AVAILABLE WHEEL TYPES (for full specs refer to pages indicated)



NY = p89

ER = p102

CR = p104

PT = p111

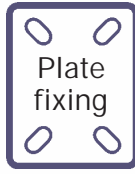
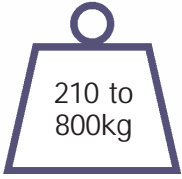
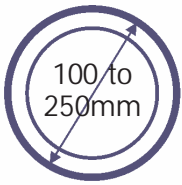

WHEEL CODE		NY	ER	CR	PT					
Wheel diam (mm)	Swivel or fixed	Tread width (mm)	Overall height (mm)	Plate type	Swivel radius (mm)	Bearing type	White nylon	Black elastic rubber on aluminium	Black elastic rubber on cast iron	Brown polyurethane on cast iron

200	S	50 NY=45	239	A	155		BZP200NY 800kg	-	-	-
							BZP200NYB 800kg	-	BZP200CRB 450kg	BZP200PTB 800kg
							BZP200NYBJ 800kg	BZP200ERBJ 450kg	BZP200CRBJ 450kg	BZP200PTBJ 800kg
200	F	50 NY=45	239	A	-		BZPF200NY 800kg	-	-	-
							BZPF200NYB 800kg	-	BZPF200CRB 450kg	BZPF200PTB 800kg
							BZPF200NYBJ 800kg	BZPF200ERBJ 450kg	BZPF200CRBJ 450kg	BZPF200PTBJ 800kg
250	S	50	292	A	180		BZP250NY 800kg	-	-	-
							-	-	-	-
							BZP250NYBJ 800kg	BZP250ERBJ 500kg	BZP250CRBJ 500kg	BZP250PTBJ 800kg
250	F	50	292	A	-		BZPF250NY 800kg	-	-	-
							-	-	-	-
							BZPF250NYBJ 800kg	BZPF250ERBJ 500kg	BZPF250CRBJ 500kg	BZPF250PTBJ 800kg

PLATE TYPES AND DIMENSIONS (mm)

Type A

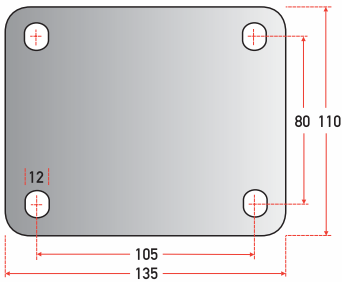

- Nutted kingpin swivel head for added strength

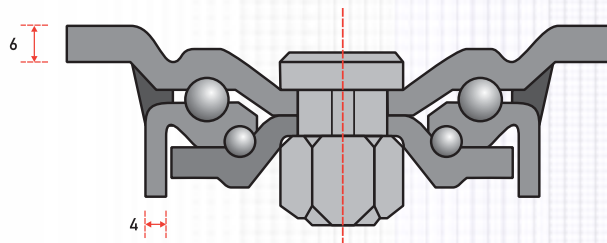



BZJ SERIES

Housing and plate made of fabricated passivated steel with double ball race in swivelhead.

Available with top plate fixing.

WHEEL CODE						NY	PT	NP	CI	CR	
Wheel diam (mm)	Swivel or fixed	Tread width (mm)	Overall height (mm)	Plate type	Swivel radius (mm)	Bearing type	White nylon	Brown polyurethane on cast iron	Red polyurethane on white nylon	Black painted cast iron	Black elastic rubber on cast iron

100	S	50 NY=35 PT=40	143	A	90 124*	BZJ100NY 400kg	-	-	BZJ100CI 400kg	-
						-	-	-	BZJ100CIB 400kg	-
						BZJ100NYBJ 400kg	BZJ100PTBJ 300kg	-	BZJ100CIBJ 400kg	BZJ100CRBJ 210kg
100	F	50 NY=35 PT=40	143	A	-	BZJF100NY 400kg	-	-	BZJF100CI 400kg	-
						-	-	-	BZJF100CIB 400kg	-
						BZJF100NYBJ 400kg	BZJF100PTBJ 300kg	-	BZJF100CIBJ 400kg	BZJF100CRBJ 210kg
125	S	50 NY=45 NP=40	165	A	103 124*	BZJ125NY 400kg	-	BZJ125NP 350kg	BZJ125CI 400kg	BZJ125CR 300kg
						BZJ125NYB 400kg	-	BZJ125NPB 350kg	BZJ125CIB 400kg	BZJ125CRB 300kg
						BZJ125NYBJ 400kg	BZJ125PTBJ 400kg	BZJ125NPBJ 350kg	BZJ125CIBJ 400kg	BZJ125CRBJ 300kg
125	F	50 NY=45 NP=40	165	A	-	BZJF125NY 400kg	-	BZJF125NP 350kg	BZJF125CI 400kg	BZJF125CR 300kg
						BZJF125NYB 400kg	-	BZJF125NPB 350kg	BZJF125CIB 400kg	BZJF125CRB 300kg
						BZJF125NYBJ 400kg	BZJF125PTBJ 400kg	BZJF125NPBJ 350kg	BZJF125CIBJ 400kg	BZJF125CRBJ 300kg
150	S	50 NY=45 NP=40	190	A	126	BZJ150NY 400kg	-	BZJ150NP 400kg	BZJ150CI 400kg	BZJ150CR 300kg
						BZJ150NYB 400kg	BZJ150PTB 400kg	BZJ150NPB 400kg	BZJ150CIB 400kg	BZJ150CRB 300kg
						BZJ150NYBJ 400kg	BZJ150PTBJ 400kg	BZJ150NPBJ 400kg	BZJ150CIBJ 400kg	BZJ150CRBJ 300kg
150	F	50 NY=45 NP=40	190	A	-	BZJF150NY 400kg	-	BZJF150NP 400kg	BZJF150CI 400kg	BZJF150CR 300kg
						BZJF150NYB 400kg	BZJF150PTB 400kg	BZJF150NPB 400kg	BZJF150CIB 400kg	BZJF150CRB 300kg
						BZJF150NYBJ 400kg	BZJF150PTBJ 400kg	BZJF150NPBJ 400kg	BZJF150CIBJ 400kg	BZJF150CRBJ 300kg
200	S	50	240	A	154	BZJ200NY 400kg	-	BZJ200NP 400kg	BZJ200CI 400kg	BZJ200CR 400kg
						BZJ200NYB 400kg	BZJ200PTB 400kg	BZJ200NPB 400kg	BZJ200CIB 400kg	BZJ200CRB 400kg
						BZJ200NYBJ 400kg	BZJ200PTBJ 400kg	BZJ200NPBJ 400kg	BZJ200CIBJ 400kg	BZJ200CRBJ 400kg
200	F	50	240	A	-	BZJF200NY 400kg	-	BZJF200NP 400kg	BZJF200CI 400kg	BZJF200CR 400kg
						BZJF200NYB 400kg	BZJF200PTB 400kg	BZJF200NPB 400kg	BZJF200CIB 400kg	BZJF200CRB 400kg
						BZJF200NYBJ 400kg	BZJF200PTBJ 400kg	BZJF200NPBJ 400kg	BZJF200CIBJ 400kg	BZJF200CRBJ 400kg

Braked castors (side-mounted wheelbrake)

add to code: BK

For directional lock fitting

add to code: DL

* Swivel radius when brakes are fitted

WHEEL BEARING KEY

- Plain bore
- Needle roller
- Ball journal

AVAILABLE WHEEL TYPES (for full wheel specifications refer to pages indicated)

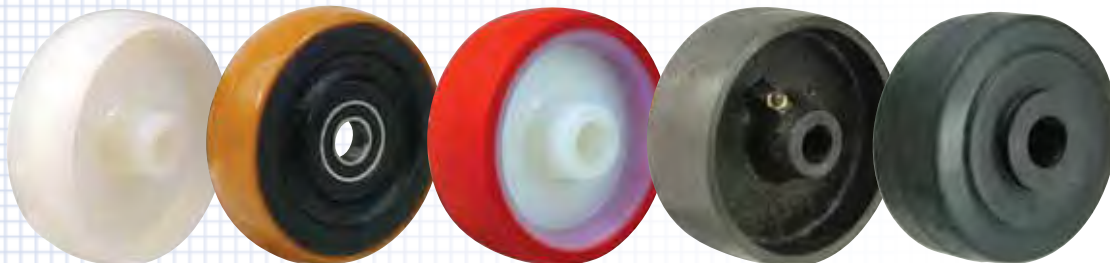

NY = p89

PT = p111

NP = p106

CI = p90

CR = p104

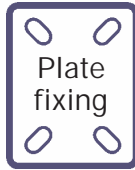
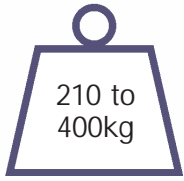
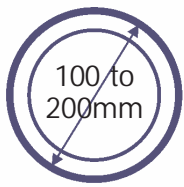

210-400kg

PLATE TYPES AND DIMENSIONS (mm)

Type A

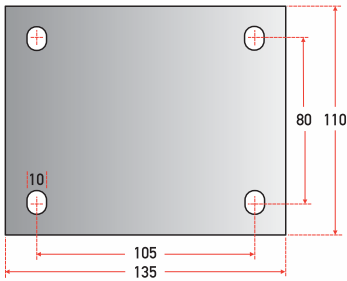

- 19mm high tensile kingpin
- Larger ball race
- Case hardened ball race
- 5.5mm thick legs welded on the outside
- 60mm fork width

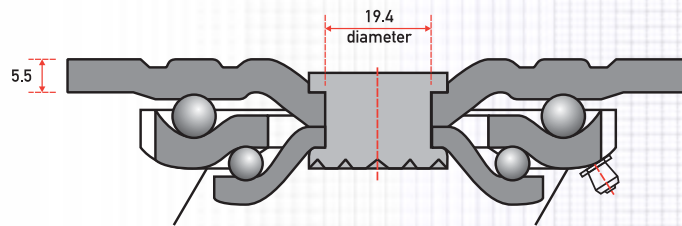

BZJ SERIES INDUSTRIAL





BZMJ SERIES

Housing and plate made of fabricated zinc-plated steel with double ball race in swivelhead.

Available with top plate fixing.

WHEEL CODE		NY	PT	NP	CI	CR					
Wheel diam (mm)	Swivel or fixed	Tread width (mm)	Overall height (mm)	Plate type	Swivel radius (mm)	Bearing type	White nylon	Brown polyurethane on cast iron	Red polyurethane on white nylon	Black painted cast iron	Black elastic rubber on cast iron

100	S	50 NY=35 PT=40	143	A	85 110*	BZMJ100NY 400kg	-	-	BZMJ100CI 400kg	-
						-	-	-	BZMJ100CIB 400kg	-
						BZMJ100NYBJ 400kg	BZMJ100PTBJ 300kg	-	BZMJ100CIBJ 400kg	BZMJ100CRBJ 210kg
100	F	50 NY=35 PT=40	143	A	-	BZMJF100NY 400kg	-	-	BZMJF100CI 400kg	-
						-	-	-	BZMJF100CIB 400kg	-
						BZMJF100NYBJ 400kg	BZMJF100PTBJ 300kg	-	BZMJF100CIBJ 400kg	BZMJF100CRBJ 210kg
125	S	50 NY=45 NP=40	165	A	108 110*	BZMJ125NY 600kg	-	BZMJ125NP 350kg	BZMJ125CI 600kg	-
						BZMJ125NYB 600kg	-	BZMJ125NPB 350kg	BZMJ125CIB 600kg	-
						BZMJ125NYBJ 600kg	BZMJ125PTBJ 400kg	BZMJ125NPBJ 350kg	BZMJ125CIBJ 600kg	BZMJ125CRBJ 300kg
125	F	50 NY=45 NP=40	165	A	-	BZMJF125NY 600kg	-	BZMJF125NP 350kg	BZMJF125CI 600kg	-
						BZMJF125NYB 600kg	-	BZMJF125NPB 350kg	BZMJF125CIB 600kg	-
						BZMJF125NYBJ 600kg	BZMJF125PTBJ 400kg	BZMJF125NPBJ 350kg	BZMJF125CIBJ 600kg	BZMJF125CRBJ 300kg
150	S	50 NY=45 NP=40	190	A	120 150*	BZMJ150NY 600kg	-	BZMJ150NP 500kg	BZMJ150CI 600kg	BZMJ150CR 300kg
						BZMJ150NYB 600kg	BZMJ150PTB 600kg	BZMJ150NPB 500kg	BZMJ150CIB 600kg	BZMJ150CRB 300kg
						BZMJ150NYBJ 600kg	BZMJ150PTBJ 600kg	BZMJ150NPBJ 500kg	BZMJ150CIBJ 600kg	BZMJ150CRBJ 300kg
150	F	50 NY=45 NP=40	190	A	-	BZMJF150NY 600kg	-	BZMJF150NP 500kg	BZMJF150CI 600kg	BZMJF150CR 300kg
						BZMJF150NYB 600kg	BZMJF150PTB 600kg	BZMJF150NPB 500kg	BZMJF150CIB 600kg	BZMJF150CRB 300kg
						BZMJF150NYBJ 600kg	BZMJF150PTBJ 600kg	BZMJF150NPBJ 500kg	BZMJF150CIBJ 600kg	BZMJF150CRBJ 300kg
200	S	50	240	A	160 145*	BZMJ200NY 600kg	-	BZMJ200NP 600kg	BZMJ200CI 600kg	BZMJ200CR 450kg
						BZMJ200NYB 600kg	BZMJ200PTB 600kg	BZMJ200NPB 600kg	BZMJ200CIB 600kg	BZMJ200CRB 450kg
						BZMJ200NYBJ 600kg	BZMJ200PTBJ 600kg	BZMJ200NPBJ 600kg	BZMJ200CIBJ 600kg	BZMJ200CRBJ 450kg
200	F	50	240	A	-	BZMJF200NY 600kg	-	BZMJF200NP 600kg	BZMJF200CI 600kg	BZMJF200CR 450kg
						BZMJF200NYB 600kg	BZMJF200PTB 600kg	BZMJF200NPB 600kg	BZMJF200CIB 600kg	BZMJF200CRB 450kg
						BZMJF200NYBJ 600kg	BZMJF200PTBJ 600kg	BZMJF200NPBJ 600kg	BZMJF200CIBJ 600kg	BZMJF200CRBJ 450kg

Braked castors (swivel and wheelbrake)

add to code: SWB

For directional lock fitting

add to code: DL

* Swivel radius when brakes are fitted

WHEEL BEARING KEY

- Plain bore
- Needle roller
- Ball journal

AVAILABLE WHEEL TYPES (for full wheel specifications refer to pages indicated)

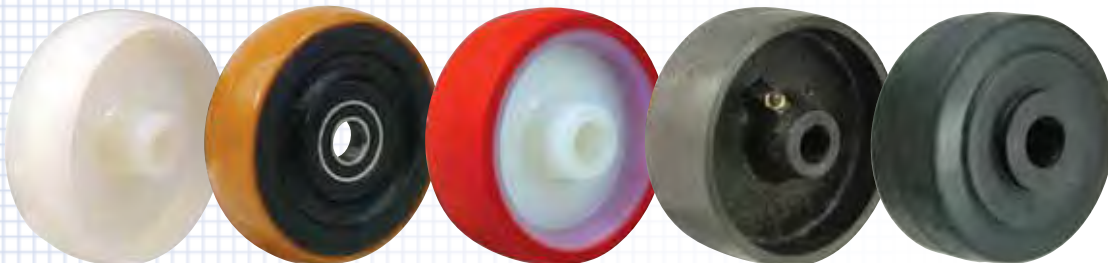

NY = p89

PT = p111

NP = p106

CI = p90

CR = p104

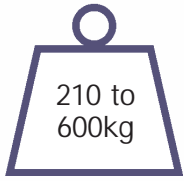
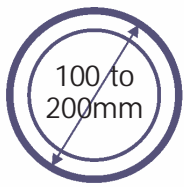
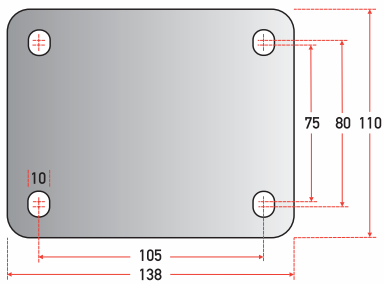

PLATE TYPES AND DIMENSIONS (mm)

Type A



- Single piece hot-forged alloy steel top plate
- Integrally forged kingpin
- Forged lower raceway
- Sealed double ball raceways
- Precision CNC-machined raceways
- Induction-hardened main raceways
- 6mm thick legs robotically welded inside and outside
- 12mm wheel axle
- Zinc passivated finish



Directional lock fitting





BZKL SERIES

Housing and plate made of fabricated black-painted steel with sealed ball race in swivelhead.

Available with top plate fixing.

WHEEL CODE		NY	PT	CR	CI					
Wheel diam (mm)	Swivel or fixed	Tread width (mm)	Overall height (mm)	Plate type	Swivel radius (mm)	Bearing type	White nylon	Brown polyurethane on cast iron	Black elastic rubber on cast iron	Black painted cast iron
100	S	50 NY=35 PT=40	140	A	77 110*	BZKL100NY 400kg	-	-	-	BZKL100CI 400kg
						-	-	-	BZKL100CIB 400kg	
						BZKL100NYBJ 400kg	BZKL100PTBJ 300kg	BZKL100CRBJ 210kg	BZKL100CIBJ 400kg	
100	F	50 NY=35 PT=40	140	A	-	BZKFL100NY 400kg	-	-	-	BZKFL100CI 400kg
						-	-	-	BZKFL100CIB 400kg	
						BZKFL100NYBJ 400kg	BZKFL100PTBJ 300kg	BZKFL100CRBJ 210kg	BZKFL100CIBJ 400kg	
125	S	50 NY=45 NP=40	165	A	95 110*	BZKL125NY 600kg	-	-	-	BZKL125CI 550kg
						BZKL125NYB 600kg	-	-	BZKL125CIB 550kg	
						BZKL125NYBJ 600kg	BZKL125PTBJ 400kg	BZKL125CRBJ 300kg	BZKL125CIBJ 550kg	
125	F	50 NY=45 NP=40	165	A	-	BZKFL125NY 600kg	-	-	-	BZKFL125CI 550kg
						BZKFL125NYB 600kg	-	-	BZKFL125CIB 550kg	
						BZKFL125NYBJ 600kg	BZKFL125PTBJ 400kg	BZKFL125CRBJ 300kg	BZKFL125CIBJ 550kg	
150	S	50 NY=45 NP=40	195	A	115 150*	BZKL150NY 800kg	-	-	BZKL150CR 300kg	BZKL150CI 800kg
						BZKL150NYB 800kg	BZKL150PTB 750kg	BZKL150CRB 300kg	BZKL150CIB 800kg	
						BZKL150NYBJ 800kg	BZKL150PTBJ 750kg	BZKL150CRBJ 300kg	BZKL150CIBJ 800kg	
150	F	50 NY=45 NP=40	195	A	-	BZKFL150NY 800kg	-	-	BZKFL150CR 300kg	BZKFL150CI 800kg
						BZKFL150NYB 800kg	BZKFL150PTB 750kg	BZKFL150CRB 300kg	BZKFL150CIB 800kg	
						BZKFL150NYBJ 800kg	BZKFL150PTBJ 750kg	BZKFL150CRBJ 300kg	BZKFL150CIBJ 800kg	
200	S	50	250	A	155 155*	BZKL200NY 900kg	-	-	BZKL200CR 450kg	BZKL200CI 900kg
						BZKL200NYB 900kg	BZKL200PTB 900kg	BZKL200CRB 450kg	BZKL200CIB 900kg	
						BZKL200NYBJ 900kg	BZKL200PTBJ 900kg	BZKL200CRBJ 450kg	BZKL200CIBJ 900kg	
200	F	50	250	A	-	BZKFL200NY 900kg	-	-	BZKFL200CR 450kg	BZKFL200CI 900kg
						BZKFL200NYB 900kg	BZKFL200PTB 900kg	BZKFL200CRB 450kg	BZKFL200CIB 900kg	
						BZKFL200NYBJ 900kg	BZKFL200PTBJ 900kg	BZKFL200CRBJ 450kg	BZKFL200CIBJ 900kg	

Braked castors (swivel and wheelbrake) add to code: SWB
 For directional lock fitting add to code: DL
 Footguards available on request (150mm & 200m only) add to code: FG
 * Swivel radius when brakes are fitted

WHEEL BEARING KEY

- Plain bore
- Needle roller
- Ball journal

AVAILABLE WHEEL TYPES (for full wheel specifications refer to pages indicated)



NY = p89

PT = p111

CR = p104

CI = p90

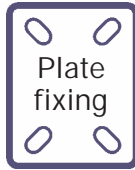
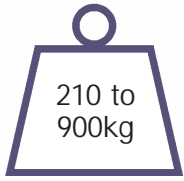
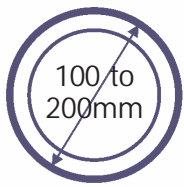

210-900kg

PLATE TYPES AND DIMENSIONS (mm)

Type A

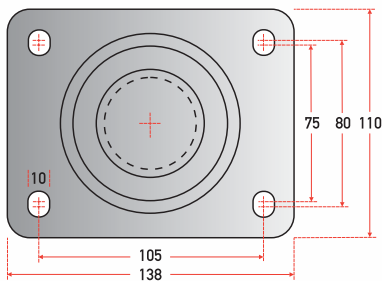

- Single piece forged alloy steel top plate and fork base
- Precision CNC-machined raceways
- Induction-hardening of raceways ensures uniform depth of hardness
- Totally sealed swivel head
- 6mm thick legs robotically welded inside and outside
- Polymer-painted black finish



Directional lock fitting

BZKL SERIES INDUSTRIAL





BZK SERIES

Housing made of fabricated black-painted steel with sealed ball race in swivelhead.

Available with top plate fixing.

WHEEL CODE		NY	PT	CR	CI					
Wheel diam (mm)	Swivel or fixed	Tread width (mm)	Overall height (mm)	Plate type	Swivel radius (mm)	Bearing type	White nylon	Brown polyurethane on cast iron	Black elastic rubber on cast iron	Black painted cast iron
150	S	50 NY=45	200	A	127 150*	BZK150NY 800kg	-	-	BZK150CR 300kg	BZK150CI 910kg
						BZK150NYB 800kg	BZK150PTB 750kg	BZK150CRB 300kg	BZK150CIB 910kg	
						BZK150NYBJ 800kg	BZK150PTBJ 750kg	BZK150CRBJ 300kg	BZK150CIBJ 910kg	
150	F	50 CR=60	200	A	-	BZKF150NY 800kg	-	-	BZKF150CR 300kg	BZKF150CI 910kg
						BZKF150NYB 800kg	BZKF150PTB 750kg	BZKF150CRB 300kg	BZKF150CIB 910kg	
						BZKF150NYBJ 800kg	BZKF150PTBJ 750kg	BZKF150CRBJ 300kg	BZKF150CIBJ 910kg	
200	S	50 CR=60	250	A	170 170*	BZK200NY 1000kg	-	-	-	BZK200CI 1000kg
						BZK200NYB 1000kg	BZK200PTB 1000kg	-	BZK200CIB 1000kg	
						BZK200NYBJ 1000kg	BZK200PTBJ 1000kg	BZK200CRBJ 600kg	BZK200CIBJ 1000kg	
200	F	50 CR=60	250	A	-	BZKF200NY 1000kg	-	-	-	BZKF200CI 1000kg
						BZKF200NYB 1000kg	BZKF200PTB 1000kg	-	BZKF200CIB 1000kg	
						BZKF200NYBJ 1000kg	BZKF200PTBJ 1000kg	BZKF200CRBJ 600kg	BZKF200CIBJ 1000kg	
250	S	50 PT=60	300	A	200 200*	BZK250NY 930kg	-	-	-	-
						-	-	-	-	
						BZK250NYBJ 1200kg	BZK250PTBJ 1400kg	BZK250CRBJ 500kg	BZK250CIBJ 1250kg	
250	F	50 PT=60	300	A	-	BZKF250NY 930kg	-	-	-	-
						-	-	-	-	
						BZKF250NYBJ 1200kg	BZKF250PTBJ 1400kg	BZKF250CRBJ 500kg	BZKF250CIBJ 1250kg	

Braked castors (swivel and wheelbrake)

add to code: SWB

For directional lock fitting

add to code: DL

Footguards available on request (150mm & 200m only)

add to code: FG

* Swivel radius when brakes are fitted

WHEEL BEARING KEY

- Plain bore
- Needle roller
- Ball journal

AVAILABLE WHEEL TYPES (for full wheel specifications refer to pages indicated)

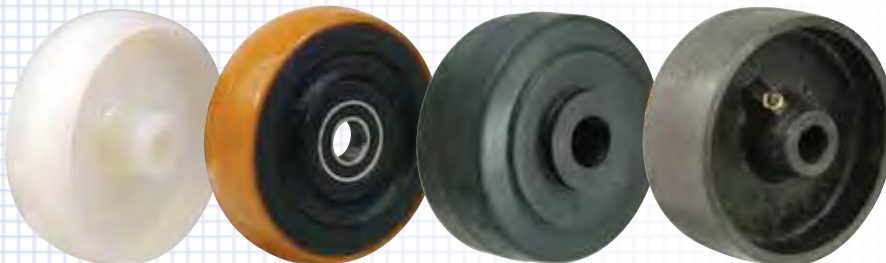

NY = p89

PT = p111

CR = p104

CI = p90

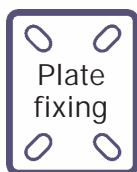
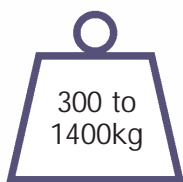
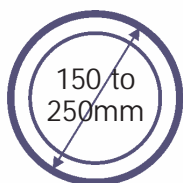

300-1400kg

PLATE TYPES AND DIMENSIONS (mm)

Type A

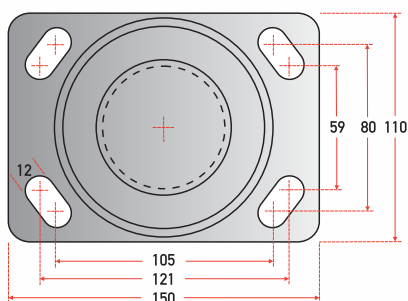

- Single piece forged alloy steel top plate and fork base
- Precision CNC-machined raceways
- Induction-hardening of raceways ensures uniform depth of hardness
- Totally sealed swivel head with grease nipple
- 6mm thick legs cylindrically-formed – robotically welded inside and outside
- Polymer-painted black finish



Directional lock fitting





2BZK SERIES

Housing made of fabricated black-painted steel with sealed ball race in swivelhead.

Available with top plate fixing.

WHEEL CODE		PT	NY	CI	CR					
Wheel diam or fixed (mm)	Swivel or fixed	Tread width (mm)	Overall height (mm)	Plate type	Swivel radius (mm)	Bearing type	Brown polyurethane on cast iron	White nylon	Black painted cast iron	Black elastic painted cast iron
125	S	38 NY=40 PT=40	175	A	98		-	2BZK125NY 700kg	-	-
							-	2BZK125NYB 700kg	-	-
							2BZK125PTBJ 800kg	2BZK125NYBJ 700kg	2BZK125CIBJ 900kg	2BZK125CRBJ 360kg
125	F	38 NY=40 PT=40	175	B	-		-	2BZKF125NY 700kg	-	-
							-	2BZKF125NYB 700kg	-	-
							2BZKF125PTBJ 800kg	2BZKF125NYBJ 700kg	2BZKF125CIBJ 900kg	2BZKF125CRBJ 360kg
150	S	50 NY=45	200	A	135		-	2BZK150NY 1500kg	2BZK150CI 1500kg	2BZK150CR 600kg
							2BZK150PTB 1500kg	2BZK150NYB 1500kg	2BZK150CIB 1500kg	2BZK150CRB 600kg
							2BZK150PTBJ 1500kg	2BZK150NYBJ 1500kg	2BZK150CIBJ 1500kg	2BZK150CRBJ 600kg
150	F	50 NY=45	200	B	-		-	2BZKF150NY 1500kg	2BZKF150CI 1500kg	2BZKF150CR 600kg
							2BZKF150PTB 1500kg	2BZKF150NYB 1500kg	2BZKF150CIB 1500kg	2BZKF150CRB 600kg
							2BZKF150PTBJ 1500kg	2BZKF150NYBJ 1500kg	2BZKF150CIBJ 1500kg	2BZKF150CRBJ 600kg
200	S	50 CR=60	250	A	165		-	2BZK200NY 1500kg	2BZK200CI 1500kg	-
							2BZK200PTB 1500kg	2BZK200NYB 1500kg	2BZK200CIB 1500kg	-
							2BZK200PTBJ 1500kg	2BZK200NYBJ 1500kg	2BZK200CIBJ 1500kg	2BZK200CRBJ 1200kg
200	F	50 CR=60	250	B	-		-	2BZKF200NY 1500kg	2BZKF200CI 1500kg	-
							2BZKF200PTB 1500kg	2BZKF200NYB 1500kg	2BZKF200CIB 1500kg	-
							2BZKF200PTBJ 1500kg	2BZKF200NYBJ 1500kg	2BZKF200CIBJ 1500kg	2BZKF200CRBJ 1200kg



Braked castors (trailing wheel lock)

add to code: BR

For directional lock fitting

add to code: DL

WHEEL BEARING KEY

-  Plain bore
-  Needle roller
-  Ball journal

AVAILABLE WHEEL TYPES (for full wheel specifications refer to pages indicated)



PT = p111

NY = p89

CI = p90

CR = p104

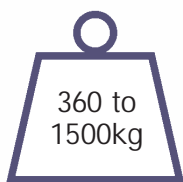
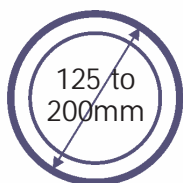

360-1500kg

PLATE TYPES AND DIMENSIONS (mm)

Type A

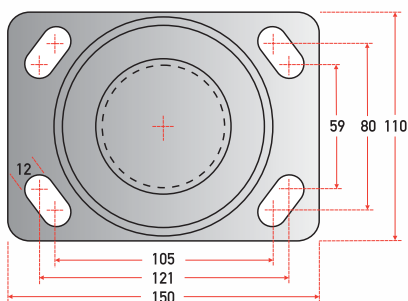

Type B

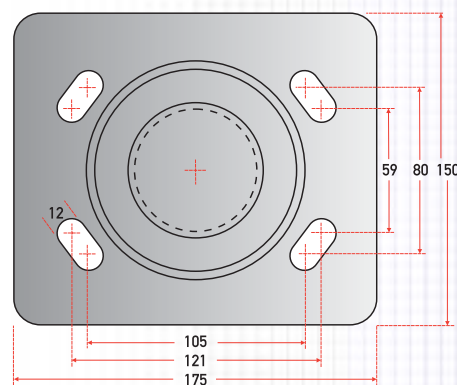

- Single piece forged alloy steel top plate and fork base
- Precision CNC-machined raceways
- Induction-hardening of raceways ensures uniform depth of hardness
- Totally sealed swivel head with grease nipple
- 6mm thick legs cylindrically-formed – robotically welded inside and outside
- Polymer-painted black finish



Directional lock fitting

2BZK SERIES INDUSTRIAL





BZQ SERIES

Housing made of fabricated black-painted steel with kingpin, thrust ball bearing and taper roller bearing in swivelhead.

Available with top plate fixing.

WHEEL CODE		PT	CI	CR					
Wheel diam (mm)	Swivel or fixed	Tread width (mm)	Overall height (mm)	Plate type	Swivel radius (mm)	Bearing type	Brown polyurethane on cast iron	Black painted cast iron	Black elastic rubber on cast iron
150	S	50	212	A	130	Needle roller	BZQ150PTB 750kg	BZQ150CIB 1000kg	BZQ150CRB 300kg
							BZQ150PTBJ 750kg	BZQ150CIBJ 1000kg	BZQ150CRBJ 300kg
150	F	50	212	A	-	Ball journal	BZQF150PTB 750kg	BZQF150CIB 1000kg	BZQF150CRB 300kg
							BZQF150PTBJ 750kg	BZQF150CIBJ 1000kg	BZQF150CRBJ 300kg
200	S	50 CR=60	264	A	167	Needle roller	BZQ200PTB/50 1100kg	BZQ200CIB/50 1100kg	-
					175*		BZQ200PTBJ/50 1100kg	BZQ200CIBJ/50 1100kg	BZQ200CRBJ/60 600kg
200	F	50 CR=60	264	A	-	Ball journal	BZQF200PTB/50 1100kg	BZQF200CIB/50 1100kg	-
							BZQF200PTBJ/50 1100kg	BZQF200CIBJ/50 1100kg	BZQF200CRBJ/60 600kg
200	S	75	264	A	175*	Ball journal	BZQ200PTBJ 1400kg	-	BZQ200CRBJ 600kg
200	F		264	A	-		BZQF200PTBJ 1400kg	-	BZQF200CRBJ 600kg
250	S	50 PT=60	314	A	205	Ball journal	BZQ250PTBJ/60 1400kg	BZQ250CIBJ/60 1400kg	BZQ250CRBJ/60 500kg
					210*		BZQ250PTBJ 1800kg	-	BZQ250CRBJ 750kg
250	F	50 PT=60	314	A	-	Ball journal	BZQF250PTBJ/60 1400kg	BZQF250CIBJ/60 1400kg	BZQF250CRBJ/60 500kg
							BZQF250PTBJ 1800kg	-	BZQF250CRBJ 750kg
300	S	75	365	A	232	Ball journal	BZQ300PTBJ 2000kg	-	BZQ300CRBJ 850kg
					235*		BZQ300PTBJ 2000kg	-	BZQ300CRBJ 850kg
300	F	75	365	A	-	Ball journal	BZQF300PTBJ 2000kg	-	BZQF300CRBJ 850kg

Braked castors (swivel and wheelbrake)

add to code: SWB

For directional lock fitting

add to code: DL

WHEEL BEARING KEY

-  Needle roller
-  Ball journal

AVAILABLE WHEEL TYPES (for full wheel specifications refer to pages indicated)



PT = p111

CI = p90

CR = p104

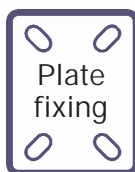
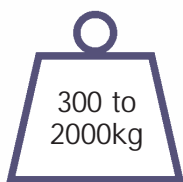
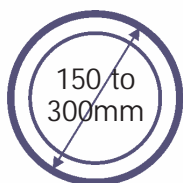

300-2000kg

PLATE TYPES AND DIMENSIONS (mm)

Type A

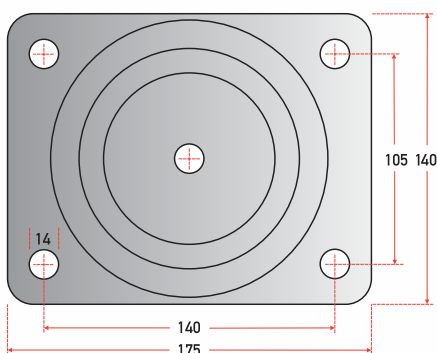

- Single piece forged alloy steel top plate with an integrally forged kingpin
- Forged fork base
- Combination of thrust ball bearing (DIN 711) and tapered roller bearing (DIN 720) in the swivel head
- Swivel head-play made adjustable by a slotted nut/cotter pin arrangement
- Totally sealed swivel head with grease nipple
- 10mm thick legs cylindrically-formed – robotically welded inside and outside
- Polymer-painted black finish



Directional lock fitting





2BZQ SERIES

Housing made of fabricated black-painted steel with kingpin, thrust ball bearing and taper roller bearing in swivelhead.

Available with top plate fixing.

WHEEL CODE

Wheel diam or (mm)

Swivel or fixed

Tread width (mm)

Overall height (mm)

Plate type

Swivel radius (mm)

Bearing type

PT

CI

NY

Brown polyurethane on cast iron

Black painted cast iron

White nylon

Wheel diam or (mm)	Swivel or fixed	Tread width (mm)	Overall height (mm)	Plate type	Swivel radius (mm)	Bearing type	PT	CI	NY
150	S	50+50	212	A	140		2BZQ150PTBJ 1500kg	2BZQ150CIBJ 1820kg	2BZQ150NYBJ 1600kg
	F	50+50	212	A	-		2BZQF150PTBJ 1500kg	2BZQF150CIBJ 1820kg	2BZQF150NYBJ 1600kg
200	S	50+50	264	A	175		2BZQ200PTBJ 2000kg	2BZQ200CIBJ 2000kg	2BZQ200NYBJ 2000kg
	F	50+50	264	A	-		2BZQF200PTBJ 2000kg	2BZQF200CIBJ 2000kg	2BZQF200NYBJ 2000kg
250	S	50+50	314	A	212		2BZQ250PTBJ 2000kg	2BZQ250CIBJ 2000kg	2BZQ250NYBJ 2000kg
	F	50+50	314	A	-		2BZQF250PTBJ 2000kg	2BZQF250CIBJ 2000kg	2BZQF250NYBJ 2000kg

For directional lock fitting

add to code: DL

WHEEL BEARING KEY

Ball journal

AVAILABLE WHEEL TYPES (for full wheel specifications refer to pages indicated)



PT = p111

CI = p90

NY = p89

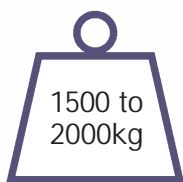
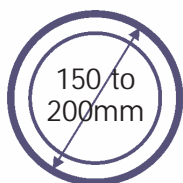

1500-2000kg

PLATE TYPES AND DIMENSIONS (mm)

Type A

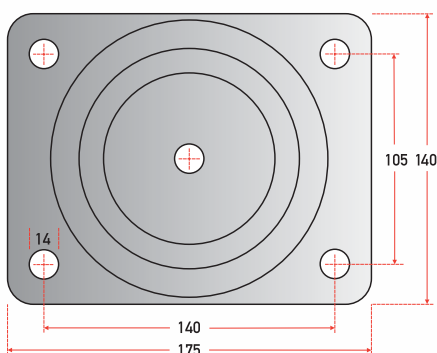

- Single piece forged alloy steel top plate with an integrally forged kingpin
- Forged fork base
- Combination of thrust ball bearing (DIN 711) and tapered roller bearing (DIN 720) in the swivel head
- Swivel head-play made adjustable by a slotted nut/cotter pin arrangement
- Totally sealed swivel head with grease nipple
- 10mm thick legs cylindrically-formed – robotically welded inside and outside
- Polymer-painted black finish



Directional lock fitting

2BZQ SERIES INDUSTRIAL





BZQXX SERIES

Housing made of fabricated black-painted steel with kingpin, thrust ball bearing and taper roller bearing in swivelhead.

Available with top plate fixing.

WHEEL CODE

Wheel diam or (mm)

Swivel fixed

Tread width (mm)

Overall height (mm)

Plate type

Swivel radius (mm)

Bearing type

PT

CR

ST

Brown polyurethane on cast iron

Black elastic rubber on cast iron

Solid steel

Wheel diam or (mm)	Swivel fixed	Tread width (mm)	Overall height (mm)	Plate type	Swivel radius (mm)	Bearing type	PT	CR	ST
200	S	100	280	A	165		BZQXX200PTBJ 2000kg	BZQXX200CRBJ 675kg	-
	F						-	-	BZQXX200STTT 3600kg
200	F	100	280	A	-		BZQXXF200PTBJ 2000kg	BZQFXX200CRBJ 675kg	-
	S						-	-	BZQFXX200STTT 3600kg
250	S	100	330	A	195		BZQXX250PTBJ 2500kg	BZQXX250CRBJ 950kg	-
	F						-	-	BZQXX250STTT 5450kg
250	F	100	330	A	-		BZQFXX250PTBJ 2500kg	BZQFXX250CRBJ 950kg	-
	S						-	-	BZQFXX250STTT 5450kg
300	S	100	395	A	235		BZQXX300PTBJ 3000kg	BZQXX300CRBJ 1000kg	-
	F						-	-	BZQXX300STTT 5500kg
300	F	100	395	A	-		BZQFXX300PTBJ 3000kg	BZQFXX300CRBJ 1000kg	-
	S						-	-	BZQFXX300STTT 5500kg
400	S	100	495	A	285		BZQXX400PTBJ 3500kg	-	-
	F						-	-	BZQFXX400PTBJ 3500kg

For directional lock fitting

add to code: DL

WHEEL BEARING KEY

- Ball journal
- Taper roller

AVAILABLE WHEEL TYPES (for full wheel specifications refer to pages indicated)

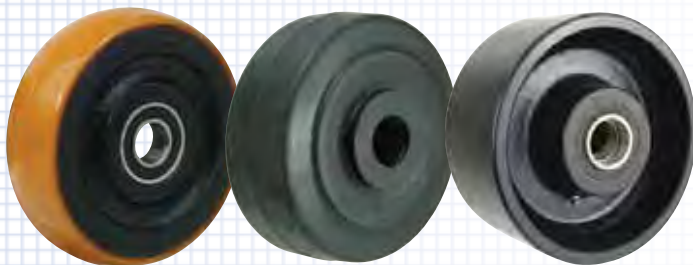

PT = p111

CR = p104

ST = p91

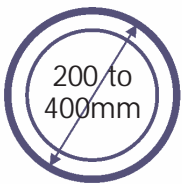
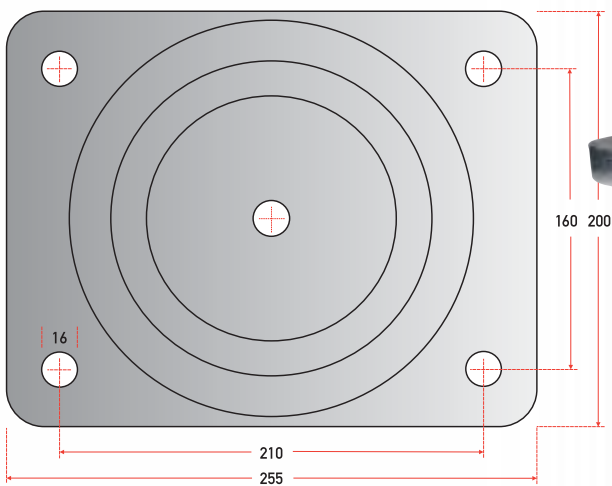

PLATE TYPES AND DIMENSIONS (mm)

Type A



- Single piece forged alloy steel top plate with an integrally forged kingpin
- Forged fork base
- Combination of thrust ball bearing (DIN 711) and tapered roller bearing (DIN 720) in the swivel head
- Swivel head-play made adjustable by a slotted nut/cotter pin arrangement
- Totally sealed swivel head with grease nipple
- 12mm thick legs cylindrically-formed – robotically welded inside and outside
- Polymer-painted black finish





2BZQX/XXH/SZ SERIES

Housing made of fabricated black-painted steel with kingpin, thrust ball bearing and taper roller bearing in swivelhead.

Available with top plate fixing.

WHEEL CODE		PT					
Wheel diam or (mm)	Swivel or fixed	Tread width (mm)	Overall height (mm)	Plate type	Swivel radius (mm)	Bearing type	Brown polyurethane on cast iron

200	S	75+75	264	A	195		2BZQX200PTBJDL 2800kg	
250	S	60+60	314	A	-		2BZQXL250PTBJ 2800kg	
	F						2BZQXFL250PTBJ 2800kg	
200	S	100+100	280	B	165		2BZXXH200PTBJ 4000kg	
	F						2BZXXHF200PTBJ 4000kg	
250	S			B	330	195		2BZXXH250PTBJ 5000kg
	F							2BZXXHF250PTBJ 5000kg
300	S			B	395	235		2BZXXH300PTBJ 6000kg
	F							2BZXXHF300PTBJ 6000kg
400	S			B	495	307		2BZXXH400PTBJ 7000kg
	F							2BZXXHF400PTBJ 7000kg
400	S	125+125	570	C	350		2BZSZ400PTM 11500kg	

PLATE TYPES AND DIMENSIONS (mm)

Type A

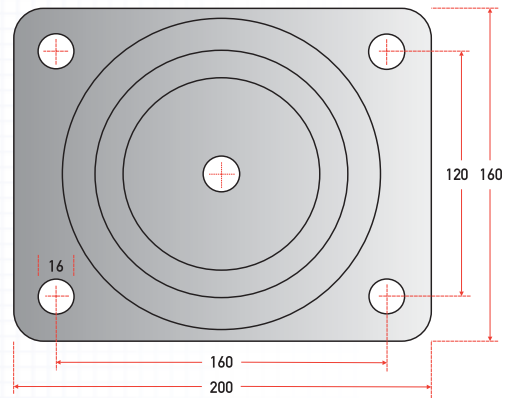

- Single piece forged alloy steel top plate with an integrally forged kingpin
- Forged fork base
- Combination of thrust ball bearing (DIN 711) and tapered roller bearing (DIN 720) in the swivel head
- Swivel head-play made adjustable by a slotted nut/cotter pin arrangement
- Totally sealed swivel head with grease nipple
- 10mm thick legs cylindrically-formed – robotically welded inside and outside
- Polymer-painted black finish

WHEEL BEARING KEY

- Ball journal
- Taper roller

AVAILABLE WHEEL TYPE (for full wheel specifications refer to page indicated)



PT = p111

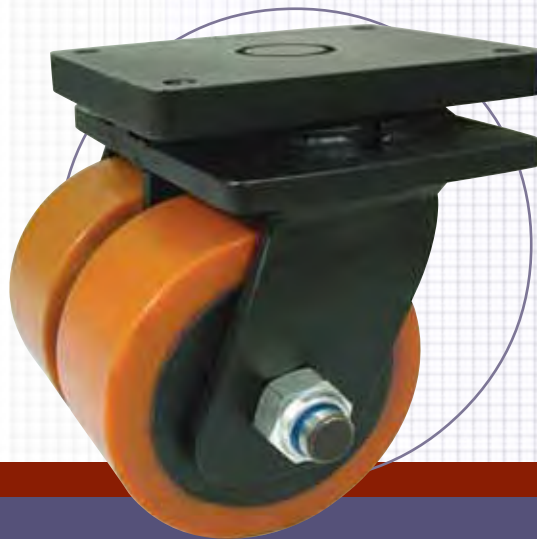
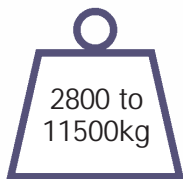
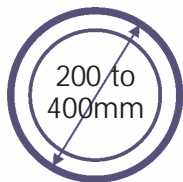

2800-11500kg

Type B

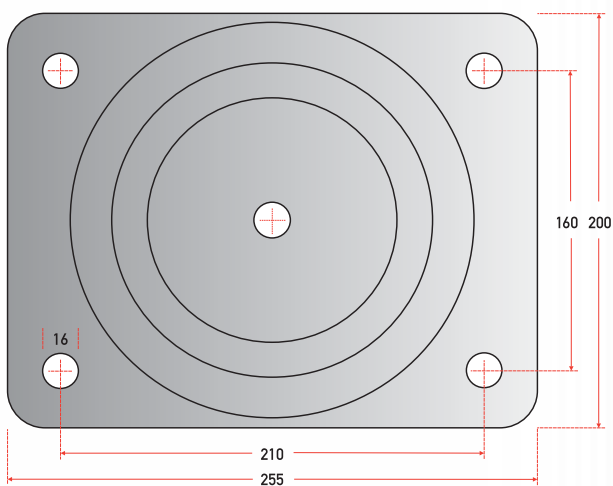

Type C

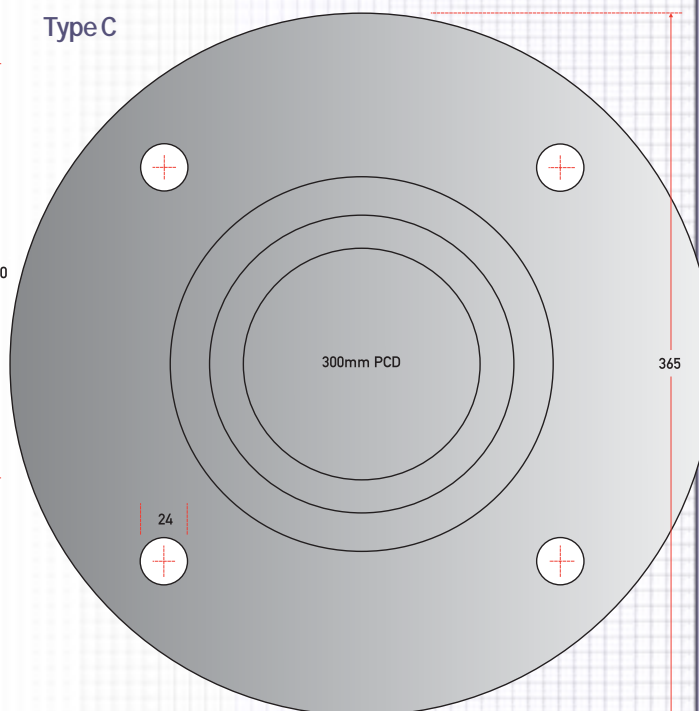

- Heavy fabricated steel top plate with an integral kingpin
- Forged fork base
- Combination of 175mm diameter thrust ball bearing (DIN 711) and 40mm tapered roller bearing (DIN 720) in the swivel head
- Swivel head-play made adjustable by a slotted nut/cotter pin arrangement
- Totally sealed swivel head with grease nipple
- 12mm thick legs cylindrically-formed – robotically welded inside and outside
- Polymer-painted black finish

- Heavy fabricated steel top plate and fork base
- Combination of opposed spherical roller thrust bearing in the swivel head allows this castor to rotate effortlessly in the most punishing conditions
- Swivel head-play made adjustable by a slotted nut/cotter pin arrangement
- Totally sealed swivel head with grease nipple
- 16mm thick legs welded inside and outside
- Polymer-painted black finish

2BZQX/2BZXXH/2BZSZ SERIES INDUSTRIAL

