



# SSMM SERIES

Housing made of pressed stainless steel (grade 304) with double ball race swivel.

Available with top plate or single bolthole fixing.

WHEEL CODE						NY	RN	NP
Wheel diam (mm)	Swivel or fixed	Tread width (mm)	Overall height (mm)	Plate type	Swivel radius (mm)	Bearing type	White nylon Blue rubber on black nylon	Red polyurethane on white nylon

80	S	25 RN=35 NP=30	105	A	78 108*	SSMM80NY 150kg	SSMM80RN 90kg	SSMM80NP 150kg
						SSMM80NYB 150kg	-	SSMM80NPB 150kg
80	F	25 RN=35 NP=30	105	A	-	SSMMF80NY 150kg	SSMMF80RN 90kg	SSMMF80NP 150kg
						SSMMF80NYB 150kg	-	SSMMF80NPB 150kg
100	S	30 RN=32	128	A	88 128*	SSMM100NY 150kg	SSMM100RN 150kg	SSMM100NP 150kg
						SSMM100NYB 150kg	SSMM100RNB 150kg	SSMM100NPB 150kg
100	F	30 RN=32	128	A	-	SSMMF100NY 150kg	SSMMF100RN 150kg	SSMMF100NP 150kg
						SSMMF100NYB 150kg	SSMMF100RNB 150kg	SSMMF100NPB 150kg
125	S	37.5 RN=35 NP=35	155	A	107 135*	SSMM125NY 200kg	SSMM125RN 200kg	SSMM125NP 200kg
						SSMM125NYB 200kg	SSMM125RNB 200kg	SSMM125NPB 200kg
125	F	37.5 RN=35 NP=35	155	A	-	SSMMF125NY 200kg	SSMMF125RN 200kg	SSMMF125NP 200kg
						SSMMF125NYB 200kg	SSMMF125RNB 200kg	SSMMF125NPB 200kg
150	S	NY=40 RN=50	190	B	135 169*	SSMM150NY 350kg	SSMM150RN 300kg	SSMM150NP 350kg
						SSMM150NYB 350kg	-	SSMM150NPB 350kg
150	F	NY=40 RN=50	190	B	-	SSMMF150NY 350kg	SSMMF150RN 300kg	SSMMF150NP 350kg
						SSMMF150NYB 350kg	-	SSMMF150NPB 350kg
160	S	45 RN=50	195	B	140 174*	SSMM160NY 350kg	SSMM160RN 300kg	-
						SSMM160NYB 350kg	-	-
160	F	45 RN=50	195	B	-	SSMMF160NY 350kg	SSMMF160RN 300kg	-
						SSMMF160NYB 350kg	-	-
200	S	50	235	B	167 188*	SSMM200NY 350kg	SSMM200RN 350kg	SSMM200NP 350kg
						SSMM200NYB 350kg	-	-
200	F	50	235	B	-	SSMMF200NY 350kg	SSMMF200RN 3750kg	SSMMF200NP 350kg
						SSMMF200NYB 350kg	-	-

Braked castors (swivel and wheelbrakes)  
Single bolthole castor 80mm to 125mm (12mm)  
\*Swivel radius when brakes are fitted

add to code: SWB  
add to code: BH12

### WHEEL BEARING KEY

- Plain bore
- Needle roller

## AVAILABLE WHEEL TYPES (for full wheel specifications refer to pages indicated)

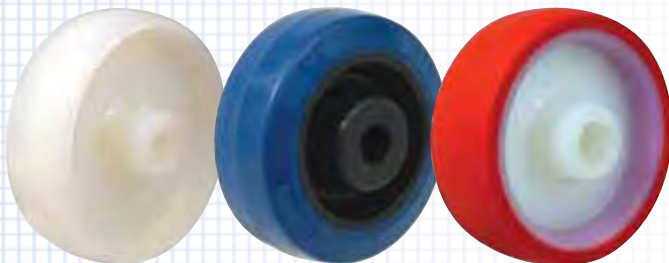

NY = p89

RN = p101

NP = p106

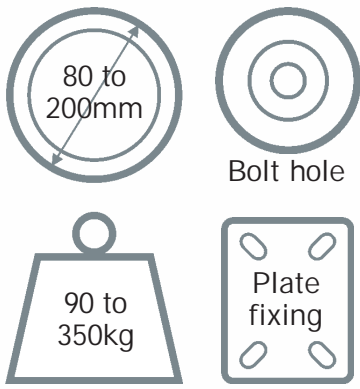

90-350kg

PLATE TYPES AND DIMENSIONS (mm)

Type A

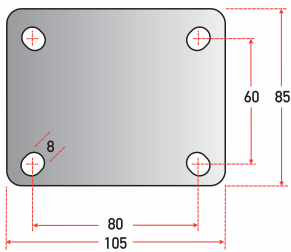

Type B

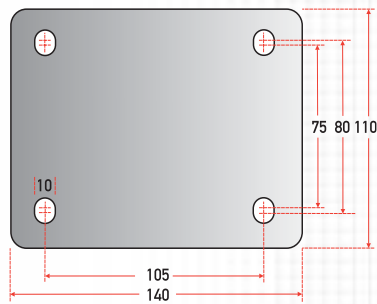

Single bolthole  
add to code: BH12

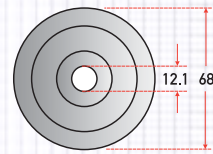

wheel diameters... 80 100 125

SSMM SERIES STAINLESS STEEL





# SSXM SERIES

Housing made of pressed stainless steel (grade 304) with sealed double ball race in swivelhead.

Available with top plate or single bolthole fixing.

WHEEL CODE		NY	RN	NP	ENP					
Wheel diam or (mm)	Swivel or fixed	Tread width (mm)	Overall height (mm)	Plate type	Swivel radius (mm)	Bearing type	White nylon	Blue elastic rubber on black nylon	Red polyurethane on white nylon	82 Shore A blue polyurethane on white nylon

80	S	35 NP=33	110	A	72	Plain bore	SSXM80NY 190kg	SSXM80RN 100kg	SSXM80NP 190kg	SSXM80ENP 190kg
						Needle roller	SSXM80NYB 190kg	–	SSXM80NPB 190kg	SSXM80ENPB 190kg
80	F	35 NP=33	110	A	–	Plain bore	SSXMF80NY 190kg	SSXMF80RN 100kg	SSXMF80NP 190kg	SSXMF80ENP 190kg
						Needle roller	SSXMF80NYB 190kg	–	SSXMF80NPB 190kg	SSXMF80ENPB 190kg
100	S	33 NY=32	130	A	88	Plain bore	SSXM100NY 210kg	SSXM100RN 160kg	SSXM100NP 210kg	SSXM100ENP 210kg
						Needle roller	SSXM100NYB 210kg	SSXM100RNB 160kg	SSXM100NPB 210kg	SSXM100ENPB 210kg
100	F	33 NY=32	130	A	–	Plain bore	SSXMF100NY 210kg	SSXMF100RN 160kg	SSXMF100NP 210kg	SSXMF100ENP 210kg
						Needle roller	SSXMF100NYB 210kg	SSXMF100RNB 160kg	SSXMF100NPB 210kg	SSXMF100ENPB 210kg
125	S	35	155	A	107	Plain bore	SSXM125NY 230kg	SSXM125RN 230kg	SSXM125NP 230kg	SSXM125ENP 230kg
						Needle roller	SSXM125NYB 230kg	SSXM125RNB 230kg	SSXM125NPB 230kg	SSXM125ENPB 230kg
125	F	35	155	A	–	Plain bore	SSXMF125NY 230kg	SSXMF125RN 230kg	SSXMF125NP 230kg	SSXMF125ENP 230kg
						Needle roller	SSXMF125NYB 230kg	SSXMF125RNB 230kg	SSXMF125NPB 230kg	SSXMF125ENPB 230kg
150	S	40	181	A	121	Plain bore	SSXM150NY 250kg	–	SSXM150NP 250kg	SSXM150ENP 250kg
						Needle roller	SSXM150NYB 250kg	–	SSXM150NPB 250kg	SSXM150ENPB 250kg
150	F	40	181	A	–	Plain bore	SSXMF150NY 250kg	–	SSXMF150NP 250kg	SSXMF150ENP 250kg
						Needle roller	SSXMF150NYB 250kg	–	SSXMF150NPB 250kg	SSXMF150ENPB 250kg
150	S	45 RN=50	183	B	127	Plain bore	SSXM150NYLP 340kg	SSXM150RNL 340kg	SSXM150NPL 340kg	SSXM150ENPL 340kg
						Needle roller	SSXM150NYBLP 340kg	–	SSXM150NPBL 340kg	SSXM150ENPBL 340kg
150	F	45 RN=50	183	B	–	Plain bore	SSXMF150NYLP 340kg	SSXMF150RNL 340kg	SSXMF150NPL 340kg	SSXMF150ENPL 340kg
						Needle roller	SSXMF150NYBLP 340kg	–	SSXMF150NPBL 340kg	SSXMF150ENPBL 340kg
200	S	50	223	B	156	Plain bore	SSXM200NY 370kg	SSXM200RN 370kg	SSXM200NP 370kg	SSXM200ENP 370kg
						Needle roller	SSXM200NYB 370kg	–	SSXM200NPB 370kg	SSXM200ENPB 370kg
200	F	50	223	B	–	Plain bore	SSXMF200NY 370kg	SSXMF200RN 370kg	SSXMF200NP 370kg	SSXMF200ENP 370kg
						Needle roller	SSXMF200NYB 370kg	–	SSXMF200NPB 370kg	SSXMF200ENPB 370kg

• Castors also available in zinc plated

Braked castors (swivel and wheelbrakes)  
 Single bolthole castor 80mm to 150mm (12mm)  
 Single bolthole castor 150mm to 200mm (16mm)  
 \*Swivel radius when brakes are fitted

add to code: SWB  
 add to code: BH12  
 add to code: BH16

### WHEEL BEARING KEY

Plain bore  
 Needle roller

## AVAILABLE WHEEL TYPES (for full wheel specifications refer to pages indicated)



NY = p89

RN = p101

NP = p106

ENP = p108

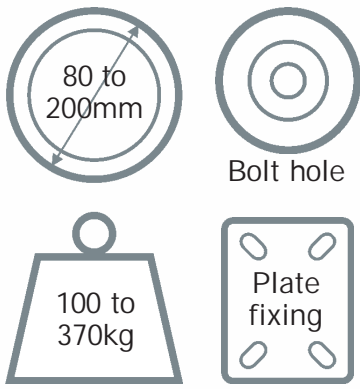

100-370kg

## PLATE TYPES AND DIMENSIONS (mm)

Type A

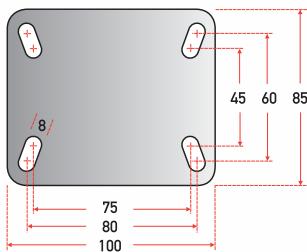

Type B

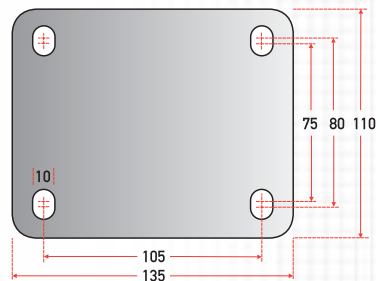

Single bolthole  
add to code: BH12

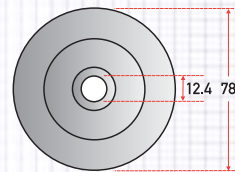

## Alternative fittings

### SQUARE EXPANDERS



Tube section	Range for inside diameter of tube (mm)	Plug length (mm)	Plug material	Product code
Square	18.5 to 21.0	70	Nylon	SSEX185/21
	21.5 to 24.0			SSEX215/24
	25.0 to 30.0			SSEX25/30

### ROUND EXPANDERS



Tube section	Range for inside diameter of tube (mm)	Plug length (mm)	Plug material	Product code
Round	18.5 to 21.0	70	Nylon	SSEX185/21
	21.5 to 24.0			SSEX215/24
	25.0 to 30.0			SSEX25/30

SSXM SERIES STAINLESS STEEL

